

PLANNING GUIDE:

FrigoPack® EC FU+/12



24.01.2019

FrigoSoft 4.7 activated: External Control with 0..10 V / 4..20 mA



FrigoPack® FU+
A New Generation



Intelligent Refrigeration Control
Systems for Compressors,
Condensers, HVAC & Pumps

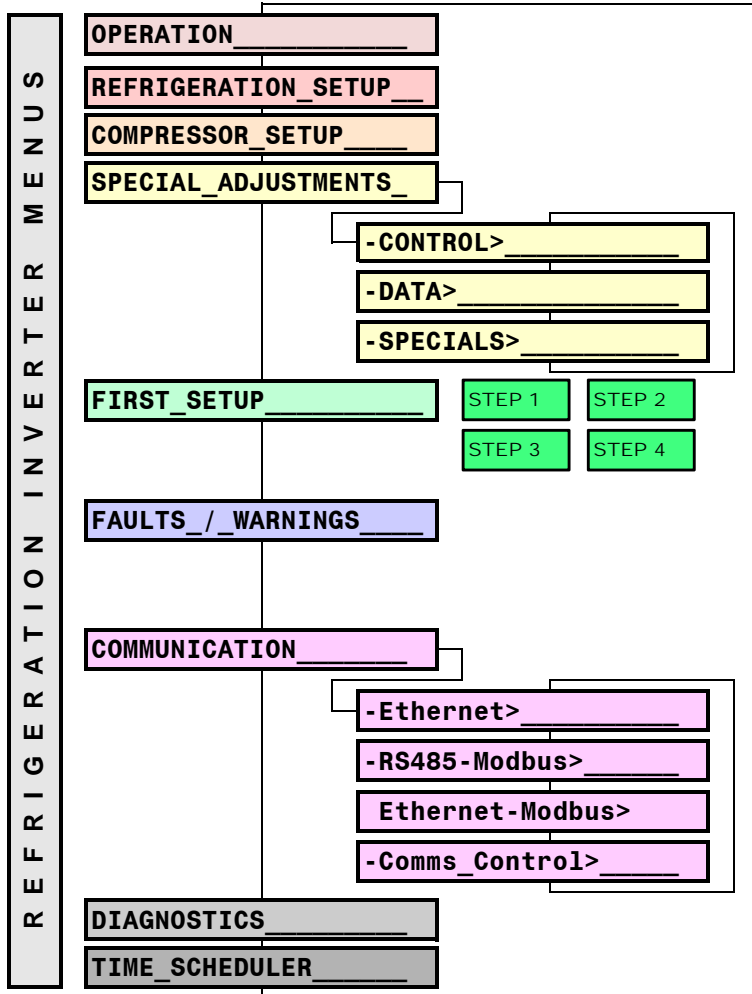

OVERVIEW OF MENUS AND INDEX

	Page
	1
Main refrigeration operating parameters <i>(observation only)</i>	2
Refrigeration setup parameters	3
Compressor setup parameters	4
Three submenus of special adjustments	5,6
Optimizing performance, setting mode of operation	..5
Special performance data	..5
Special functionality, Factory settings	..6
Refrigerant and Compressor data from the SD card	7, 20
Time and Date, Language, Units, Installation Name	7
Faults, Warnings, last 10 Trips with times	8
Trip Messages, Possible Causes, Hints for Fault Finding, Remedies	9
Communication protocols	10
ETHERNET remote communications	..10
RS485 Modbus RTU Field Bus	..10
ETHERNET Modbus	..10
External controller	..10
Diagnostics, monitoring values and serial numbers	11
Time Scheduler	20

POWER SECTION

Power connections:

- Single compressor ..12
- Single compressor with bypass(for emergency operation) ..12
- Variable-speed compressor + second larger compressor with Capacity Control ..12
- Two compressors, each with bypass and rotation ..13
- Three compressors, two Fixed-speed Compressors with rotation ..13

Power Terminals

12,13

CONTROL SECTION

Key Pad

Control connections with External Control 4...20 mA or 0...+10 V

Control and Safety circuits

10,11

14,15

16,17

FIRST TIME POWER UP

Important information

18,19

SETTING UP STEP BY STEP



20

Manufacturer	Agent / Partner	Customer	Installation	Name, Date
KIMO RHVAC Controls GmbH Hüttendorfer Weg 60 D-90768 Fürth, Germany www.frigokimo.com				

FrigoSoft 4.7 activated: External Control with 0..10 V / 4..20 mA

OPERATION

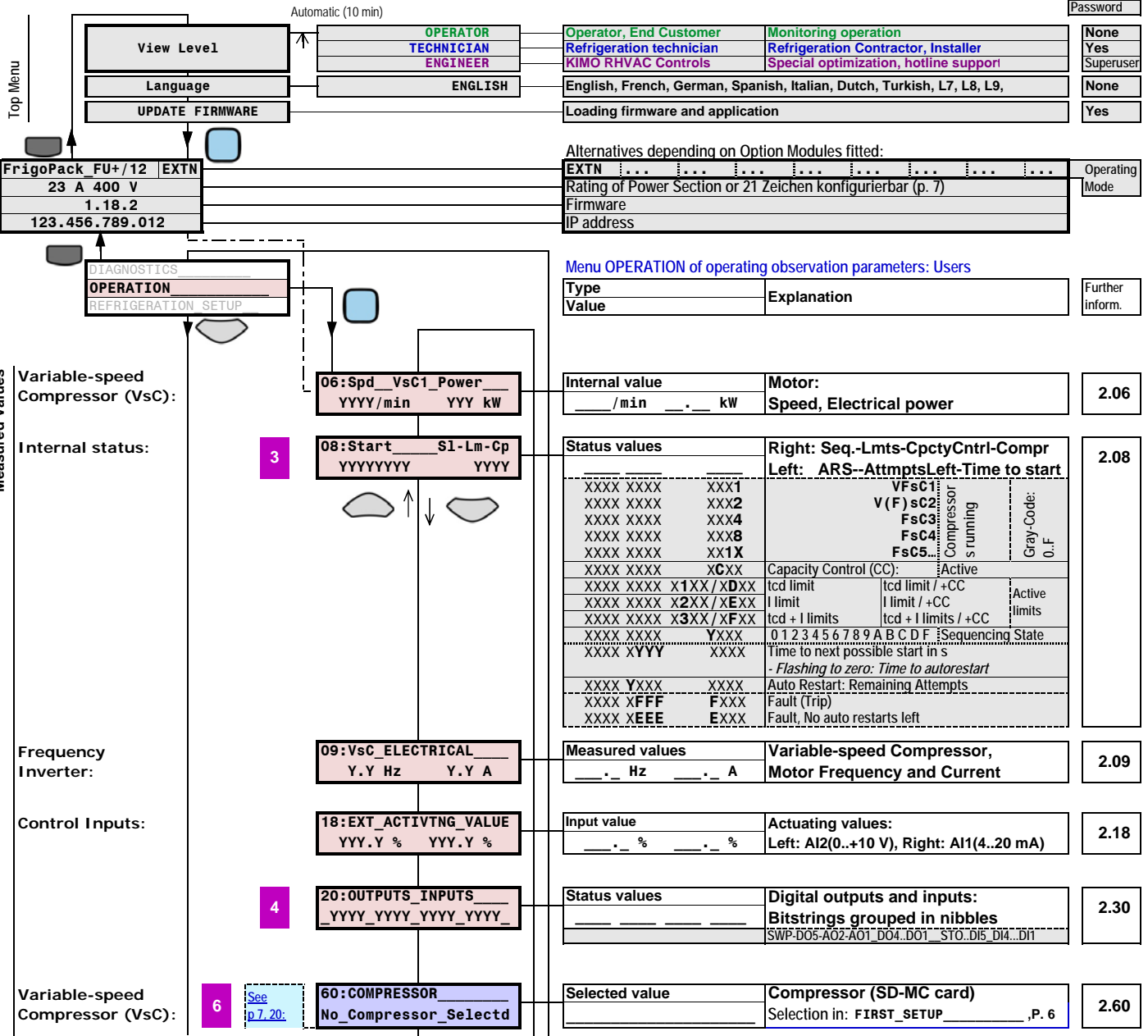

Operator, End Customer	Monitoring operation	None
Refrigeration technician	Refrigeration Contractor, Installer	Yes
KIMO RHVAC Controls	Special optimization, hotline support	Superuser
English, French, German, Spanish, Italian, Dutch, Turkish, L7, L8, L9,		None
Loading firmware and application		Yes

Alternatives depending on Option Modules fitted:

EXTN	Operating Mode
Rating of Power Section or 21 Zeichen konfigurierbar (p. 7)	
Firmware	
IP address	

Menu OPERATION of operating observation parameters: Users

Type	Explanation	Further inform.
------	-------------	-----------------

Internal value	Motor: Speed, Electrical power	2.06
____/min ____ kW		

Status values	Right: Seq.-Lmts-CpctyCntrl-Compr Left: ARS--AttmptsLeft-Time to start	2.08	
XXXX XXXX XXX1	VFsC1	Compressor s running Gray-Code: 0..F	
XXXX XXXX XXX2	V(F) sC2		
XXXX XXXX XXX4	FsC3		
XXXX XXXX XXX8	FsC4		
XXXX XXXX XX1X	FsC5		
XXXX XXXX XCXX	Capacity Control (CC): Active		
XXXX XXXX X1XX / XDXX	tcd limit	tcd limit / +CC	Active limits
XXXX XXXX X2XX / XEXX	l limit	l limit / +CC	
XXXX XXXX X3XX / XFXX	tcd + l limits	tcd + l limits / +CC	
XXXX XXXX YXXX	0 1 2 3 4 5 6 7 8 9 A B C D F	Sequencing State	
XXXX XYYY XXXX	Time to next possible start in s - Flashing to zero: Time to autorestart		
XXXX YXXX XXXX	Auto Restart: Remaining Attempts		
XXXX XFFF FXXX	Fault (Trip)		
XXXX XEEE EXXX	Fault, No auto restarts left		

Measured values	Variable-speed Compressor, Motor Frequency and Current	2.09
____ Hz ____ A		

Input value	Actuating values: Left: AI2(0..+10 V), Right: AI1(4..20 mA)	2.18
____ % ____ %		

Status values	Digital outputs and inputs: Bitstrings grouped in nibbles	2.30
_____	SWP.D05.A02.A01.D04.D01.STO.D15.D14.D11	

Selected value	Compressor (SD-MC card)	2.60
_____	Selection in: FIRST_SETUP_____,P. 6	

Optional information not required for operation

Abbreviations:	
VsC:	Variable-speed Compressor
FsC:	Fixed-speed Compressors
VFsC:	Variable- / Fixed-speed Compressor
VfG:	Variable-speed fan Group (Condenser / Dry cooler)
= YY.Y %	: Measured value depending on operating point
→ FFF	: Factory default value depending on frame size and rated power

1 ... 10 Please report these values if there are any problems

Menu COMPRESSOR SETUP for setting compressor operation:
View Level TECHNICIAN (for Refrigeration Personnel) only, see page 1

REFRIGERATION SETUP
COMPRESSOR SETUP
SPECIAL ADJUSTMENTS

Type	Explanation	Further inform.
Value		

Settings
Variable-speed Compressor (VsC):

61:VsC_CURRENT_MAX
0.0 A

Configuration Setting
VsC Motor current max
4.61

CAN ONLY BE CHANGED IF FRIGOPACK FU+ STOPPED FIRST
Preset to 1000 A until a compressor is selected, see page 7

Limits:

62:VsC_FREQUENCY_MAX
65.0 Hz

Setting VsC Motor frequency max.:
Max. settable value: Dt0, page 5
4.62 50.0 Hz

64:VsC_FREQUENCY_MIN
25.0 Hz

Setting VsC Motor frequency min.:
Min. settable value: Dt1, page 5
4.64 >5.0 Hz

65:VsC_MOTOR_NO_POLES
4

Setting VsC Motor:
No. of poles: 2, 4, 6, 8
4.65

Resonance avoidance:

66:VsC_SKIP_FREQ1_MIN
0.0 Hz

Setting VsC Resonance Avoid., Skip freq 1 min.:
10.0..65.0 Hz *
4.66

67:VsC_SKIP_FREQ1_MAX
0.0 Hz

Setting VsC Resonance Avoid., Skip freq 1 max.:
10.0..65.0 Hz *
4.67

68:VsC_SKIP_FREQ2_MIN
0.0 Hz

Setting VsC Resonance Avoid., Skip freq 2 min.:
10.0..65.0 Hz *
4.68

69:VsC_SKIP_FREQ2_MAX
0.0 Hz

Setting VsC Resonance Avoid., Skip freq 2 max.:
10.0..65.0 Hz *
4.69

* Limited to fmin..fmax and range of next band.
Set to 0.0 Hz when not in use.

Time settings:

70:VsC_tinhibit_TIME
300 s

Setting VsC Inhibit Time after VsC start:
20..1200 s
4.70

71:VsC_tlubrcn_TIME
4 s

Setting VsC Oil Lubrication Pulse time:
0..100 s
4.71

72:VsC_thld_fmin_TIME
10 s

Setting VsC Start Hold Time (at fmin):
0..120 s
4.72

Lubrication:

COMPRESSOR SETUP

Modifying

Password TECHNICIAN for Refrigeration Personnel: 8670

Menu SPECIAL ADJUSTMENTS of special parameters:
View Level TECHNICIAN (for Refrigeration Personnel) only, see page 1

COMPRESSOR SETUP
SPECIAL ADJUSTMENTS
FIRST SETUP

-CONTROL>

Settings
Controllers:

90:VsC_Voltage/Freq_ 8.00 V/Hz

96:START/STOP_LEVELS 0001

97:START_BULGE 2.0%

99:OPERATING_MODE D100

Operating Mode:

-DATA>

Controllers:

Refer to 62: & 64: on page 4

Dt0 70.0 Hz

Dt1 25.0 Hz

Dt6 20.0Hz/s 20.0Hz/s

SD Card:

Dt9 16c

Modifying

Type	Explanation	Further inform.
------	-------------	-----------------

Sub-Menu <CONTROL of Optimizing Parameters

Configuration Setting	Ratio of Voltage / Frequency, usually: 8.00: 400 V/50 Hz // 4.62: 400 V/87 Hz	56.90
-----------------------	-------------------------------------------------------------------------------	-------

Setting	Operation with an external controller: Start / Stop Pegel für special applications	56.96
0000	0...fmax continuous.	
>0000	fmin...fmax continuous	
XX01 .. XXFF	Start: 1.02..100.00%	
01XX .. FFXX	Stop if >= 1.02: 1.02..100.00%	

Setting	Optimization of starting torque: 0.0 ... 5.0 %	56.97
---------	------------------------------------------------	-------

Only change after reference to our Applications Department

Setting	Defines Operating Mode: Input as hexadecimal	56.99
Special functionality	X2XX Activate GRAY Code	
X8XX	Activate delayed Oil Injection	
1XXX	Trip reset: D11 (0->1) / 0XXX->1XXX	
2XXX	Allow slow stop ramp	
0XXX	Relay Ready No Fault	
4XXX	DO1: No Fault & Enabled	
8XXX	& D11 (Control Switch)	
CXXX	Delay OFF (15 min)	

Sub-Menu <DATA of Special Parameters

Only change after reference to our Applications Department

Configuration Setting	VsC: Motor Frequency max. settable 15.0 ... 120.0 Hz	56.Dt0
-----------------------	------------------------------------------------------	--------

Configuration Setting	VsC: Motor Frequency min. settable 15.0 ... 120.0 Hz	56.Dt1
-----------------------	------------------------------------------------------	--------

Dt0 and Dt1 change only when FrigoPack stopped. Reset by pressing the red 'O' key.

Setting	Reduce ramp rates above fmin: Acceleration Deceleration	56.Dt6
---------	---------------------------------------------------------	--------

Setting	SD Card (Secure Data Memory Card): Revision Designation	56.Dt9
---------	---------------------------------------------------------	--------

Password TECHNICIAN for Refrigeration Personnel: 8670

SPECIAL ADJUSTMENTS

-SPECIALS>

Sub-Menu <SPECIALS of Expert Parameters

Only change after reference to our Applications Department

SPECIAL

- Pressure transmitters
- Speed Setpoint Conditioning
- Further Resonance Avoidance
- Capacity Controller
- Other settings Low-ambient
- External Energy Meter
- External input Harmonic Filter
- Other settings
- Other settings
- Other settings
- Resetting values
- Factory settings
- Limiting Ranges (night operation)
- Special Purpose

Sp0	XX22	Setting	Pressure transmitters, measurement ranges: pc, pe (4...20 mA)	56.Sp0																																	
Sp1	0064	Setting	Demo tcb ted Lub.- Force Freq: 7764 = tcb ted 50.0 Hz Demo operation deviation ted: 0..F	56.Sp1																																	
Sp7	FFFF	Setting	Further Skip Frequency 3: (fmax: 127.5 Hz fmin: 127.5 Hz)	56.Sp7																																	
Sp8	FFFF	Setting	Further Skip Frequency 4: (fmax: 127.5 Hz fmin: 127.5 Hz)	56.Sp8																																	
SpC	F897	Setting	Capacity Control (solenoid valve): ton (<=300 s), toff (>=20 s)	56.SpC																																	
SpE	0000	Setting	te, tc Controllers, l time constants: LOW, min, start, Press, group in Comu.	56.SpE																																	
SpG	0000	Setting	External Energy Meter: Pulse in kW	56.SpG																																	
SpH	0000	Setting	Ext. supply filter Nibbles 1,0 (below): Release trap < value Nibbles 1,0	56.SpH																																	
			<table border="1"> <tr><td>XXX0</td><td>Normal:</td><td>Enable</td></tr> <tr><td>FFX1</td><td>Rack: Incrs fmin after time (envlp):</td><td>Enable</td></tr> <tr><td>FFX2</td><td>Scroll: Incrs fmin after time (envlp):</td><td>Enable</td></tr> <tr><td>FFX4</td><td>Expansion always:</td><td>Enable</td></tr> <tr><td>FFX8</td><td>Shaft-seal monitoring:</td><td>Enable</td></tr> <tr><td>XX0X</td><td>Frequency = Force Frequency</td><td>Select</td></tr> <tr><td>XX1X</td><td>Frequency >= Force Frequency</td><td>Select</td></tr> <tr><td>XX2X</td><td>Frequency <= Force Frequency</td><td>Select</td></tr> <tr><td>XX4X</td><td>Sump heater with FrigoPack FU+</td><td>Soon</td></tr> <tr><td>XX8X</td><td>Reserve</td><td>Enable</td></tr> <tr><td>00XX</td><td>External input harmonic filter:</td><td>Release trap</td></tr> </table>	XXX0	Normal:	Enable	FFX1	Rack: Incrs fmin after time (envlp):	Enable	FFX2	Scroll: Incrs fmin after time (envlp):	Enable	FFX4	Expansion always:	Enable	FFX8	Shaft-seal monitoring:	Enable	XX0X	Frequency = Force Frequency	Select	XX1X	Frequency >= Force Frequency	Select	XX2X	Frequency <= Force Frequency	Select	XX4X	Sump heater with FrigoPack FU+	Soon	XX8X	Reserve	Enable	00XX	External input harmonic filter:	Release trap	
XXX0	Normal:	Enable																																			
FFX1	Rack: Incrs fmin after time (envlp):	Enable																																			
FFX2	Scroll: Incrs fmin after time (envlp):	Enable																																			
FFX4	Expansion always:	Enable																																			
FFX8	Shaft-seal monitoring:	Enable																																			
XX0X	Frequency = Force Frequency	Select																																			
XX1X	Frequency >= Force Frequency	Select																																			
XX2X	Frequency <= Force Frequency	Select																																			
XX4X	Sump heater with FrigoPack FU+	Soon																																			
XX8X	Reserve	Enable																																			
00XX	External input harmonic filter:	Release trap																																			
SpI	3FFA	Setting	LOCAL Energy Saving Flux reduction Flux characteristic	56.SpI																																	
			<table border="1"> <tr><td>Base Voltage:</td><td>XXXA</td><td>F..A..0: Max(110%)..Normal(100%)..Min(80%)</td></tr> <tr><td>Energy Saving,</td><td></td><td></td></tr> <tr><td>-Max Reduction:</td><td>XXFX</td><td>F..0: None(100%)..Min(70%)</td></tr> <tr><td>-Min. acting freq.:</td><td>XFXX</td><td>0..F: fmin + (0..15 Hz)</td></tr> <tr><td>LOCAL Automatic,</td><td>0XXX</td><td>0.1 Hz / s 4XXX 2 Hz / s</td></tr> <tr><td>Sweep rate:</td><td>1XXX</td><td>0.2 Hz / s 5XXX 5 Hz / s</td></tr> <tr><td></td><td>2XXX</td><td>0.5 Hz / s 6XXX 10 Hz / s</td></tr> <tr><td></td><td>3XXX</td><td>1 Hz / s</td></tr> </table>	Base Voltage:	XXXA	F..A..0: Max(110%)..Normal(100%)..Min(80%)	Energy Saving,			-Max Reduction:	XXFX	F..0: None(100%)..Min(70%)	-Min. acting freq.:	XFXX	0..F: fmin + (0..15 Hz)	LOCAL Automatic,	0XXX	0.1 Hz / s 4XXX 2 Hz / s	Sweep rate:	1XXX	0.2 Hz / s 5XXX 5 Hz / s		2XXX	0.5 Hz / s 6XXX 10 Hz / s		3XXX	1 Hz / s										
Base Voltage:	XXXA	F..A..0: Max(110%)..Normal(100%)..Min(80%)																																			
Energy Saving,																																					
-Max Reduction:	XXFX	F..0: None(100%)..Min(70%)																																			
-Min. acting freq.:	XFXX	0..F: fmin + (0..15 Hz)																																			
LOCAL Automatic,	0XXX	0.1 Hz / s 4XXX 2 Hz / s																																			
Sweep rate:	1XXX	0.2 Hz / s 5XXX 5 Hz / s																																			
	2XXX	0.5 Hz / s 6XXX 10 Hz / s																																			
	3XXX	1 Hz / s																																			
SpJ	0000	Setting	Reset of various settings	56.SpJ																																	
			<table border="1"> <tr><td>Present Values are shown</td><td>0000</td><td>No reset</td></tr> <tr><td>in Menu DIAGNOSTICS:</td><td>116D</td><td>VsC Compr equiv. 50 Hz Shaftseal rem. time (days)</td></tr> <tr><td></td><td>2721</td><td>Fan equiv 40 °C time FP fan remng. time (days)</td></tr> <tr><td></td><td>4PPP</td><td>Reset Installation Name</td></tr> <tr><td></td><td>5PPP</td><td>Reset no. of compressor starts</td></tr> <tr><td></td><td>APPP</td><td>Set special fieldbus type</td></tr> <tr><td></td><td>CPPP</td><td>Set RS485 Modbus RTU to 9600 Baud</td></tr> <tr><td></td><td>DPPP</td><td>Release Extension Module lock</td></tr> <tr><td></td><td>EPPP</td><td>Reset webservice password to initial value</td></tr> <tr><td></td><td>FPPP</td><td>Reset to factory defaults</td></tr> </table>	Present Values are shown	0000	No reset	in Menu DIAGNOSTICS:	116D	VsC Compr equiv. 50 Hz Shaftseal rem. time (days)		2721	Fan equiv 40 °C time FP fan remng. time (days)		4PPP	Reset Installation Name		5PPP	Reset no. of compressor starts		APPP	Set special fieldbus type		CPPP	Set RS485 Modbus RTU to 9600 Baud		DPPP	Release Extension Module lock		EPPP	Reset webservice password to initial value		FPPP	Reset to factory defaults				
Present Values are shown	0000	No reset																																			
in Menu DIAGNOSTICS:	116D	VsC Compr equiv. 50 Hz Shaftseal rem. time (days)																																			
	2721	Fan equiv 40 °C time FP fan remng. time (days)																																			
	4PPP	Reset Installation Name																																			
	5PPP	Reset no. of compressor starts																																			
	APPP	Set special fieldbus type																																			
	CPPP	Set RS485 Modbus RTU to 9600 Baud																																			
	DPPP	Release Extension Module lock																																			
	EPPP	Reset webservice password to initial value																																			
	FPPP	Reset to factory defaults																																			
SpK	C8C8	Setting	Ext. Module EM 2.. Active, limits: ----VfG(links)---- --VsC(rechts)----	56.SpK																																	
SpL	X101	Setting	Special purpose L: Erw. Mod., Basic Mod., Weekday, Tlog	56.SpL																																	
SpM	2800	Setting	Special purpose M: ---RTC Trim---, Motor type, Motor fluxing	56.SpM																																	
SpN	0100	Setting	Special purpose N: Drive, see below, Reserve, Reserve	56.SpN																																	
			SpN, Nibble 2: B0: EV EM Enable; B1: Not stop; B2: Force WURM operation																																		

Nibble 3: 0: Tlog: 1..7: in s
 1: Weekday
 0: Const. Flux
 4: Stabilization
 0: Recip.
 1..3: Screw
 8: Scroll

Menu FIRST SET-UP for settings with a SD card with valid data:
View Level TECHNICIAN (for Refrigeration Personnel) only, see page 1

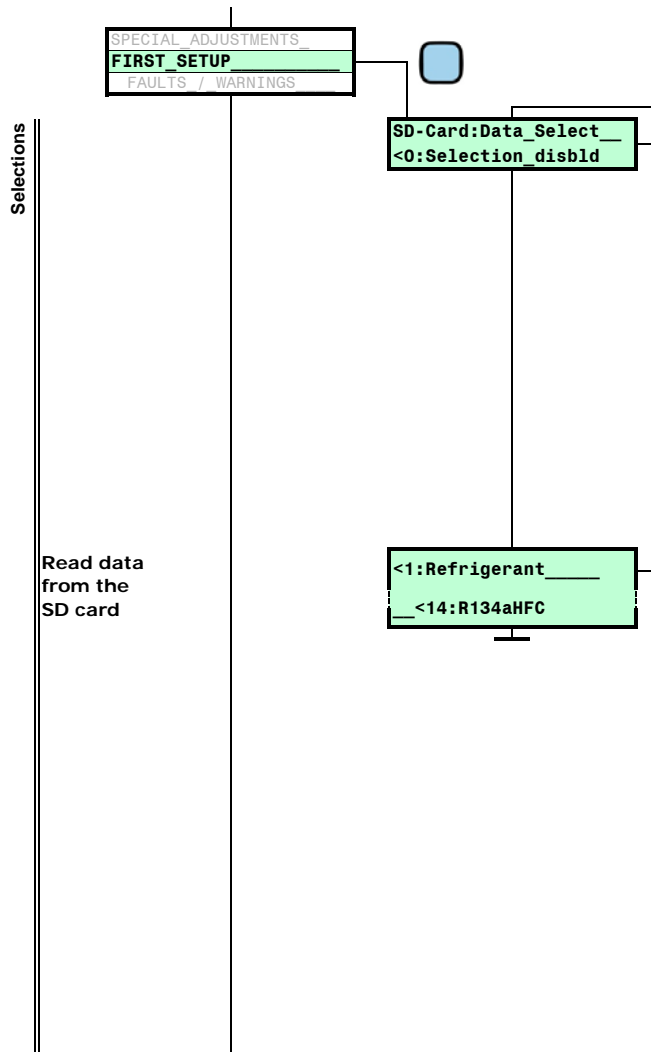

Type Value	Explanation	Further inform.
Settings:	One of the following must be activated	7.01
<0:Selection_disblD <1:Refrigerant	Selection not activated (normal) Refrigerant PRESS SOFTKEY ABOVE LEFT ON KEYPAD TO EXIT ==>DO NOT CONTINUE WITH FOLLOWING UNLESS NEW COMPRESSOR DATA REQUIRED	
<2:VFsc_Manufactur <3:VFsc_Type <4:VFsc_Cylinders <5:Motor_Voltage <6:VFsc_Compressor <<TO ENTER DATA>>	Compressor: Manufacturer Compressor: Type Compressor: Number of cylinders Electrical Supply Voltage Compressor selection <PRESS GREEN KEY ' ' >	
Selection: Tip 'DOWN' arrow key		
Settings:	Selection: Tip 'DOWN' arrow key Choice: Tip 'LEFT'/'RIGHT' arrow keys	
KEYS FOR SELECTION:	Next data set Previous data set	
IMPORTANT:	Requirement for Selection: - SD memory card with valid authorized data plugged into slot of the FU+ Refrigeration Inverter - The selection parameter SD Data_Selection must be set to: <0:Selection_disblD to return to normal operation	
REFER TO BACK PAGE FOR DETAILS		

Selectable data from the SD card	SD-MC: Secure Digital - Memory Card			
FrigoSoft 4.7: External Control with 0..10 V / 4..20 mA				
REFRIGERANT selection:				
STEP 1 → 2	R134a, R14, R22, R23, R32, R134a, R152a, R170, R227ea, R236fa, R245fa, R290 R404A, R407A, R407C, R407F, R410A, R417A, R417B, R422A, R422D, R427A, R434A, R437A, R438A, R442A, R448A, R449A, R450A, R452A, R452B, R454B, R507A, R508A, R508B, R513A, R600, R600a R717, R723, R744 sbrcr/trcrt R1150, R1234yf, R1234ze, R1270			
Compressor pre-select	<20:no_name <21:BITZER <22:CARLYLE <23:DANFOSS	<24:DORIN <25:EMERSON <26:FRASCOLD <27:FRIGOPOL	<28:GEA-Bock <29:HANBELL <2A:HITACHI <2B:J&EHALL	<2C:LGE <2D:SANYO <2E:TECUMSEH <2F:other
	<30:no_type <31:Recip_Hermetic <32:Recip_Semihermtc <33:Recip_2-stage	<34:Recip_open <35:Screw_Hermetic <36:Screw_semihermtc <37:Screw_Compact	<38:Screw_Open <39:Scroll <3A:Reserve	
	<40:No_cylinders <41:1_cylinder <42:2_cylinders <43:3_cylinders	<44:4_cylinders <46:6_cylinders	<48:8_cylinders <4A:10_cylinders	<4C:12_cylinders <4F:(15+ cylinders)
	<50:notdefined <51:50_Hz_200_V <52:50_Hz_230_V <53:50_Hz_400_V	<54:50_Hz_420_V <55:50_Hz_500_V <56:50_Hz_690_V <57:50_Hz_tbd_V	<58:60_Hz_200_V <59:60_Hz_208_V <5A:60_Hz_230_V <5B:60_Hz_380_V	<5C:60_Hz_460_V <5D:60_Hz_575_V <5E:60_Hz_660_V <5F:other
	VsC COMPRESSOR selection:			
	STUFE 2 → 3	<No_Data_selected>		

Real Time Clock:	Time and Date 2015/07/04 16:08:51	Setting Time and Date of RTC (if module A FU+ CM-1 fitted)	7.05
Language:	Language ENGLISH	Setting Set Language (If FrigoPack stopped first)	7.03
Installation ID:	Installation Name FrigoPack_FU+	Setting Welcome text in Control Menu: 21 settable characters	7.02

FIRST SETUP
FAULTS / WARNINGS
 COMMUNICATION

Measured Values

All Users

Type Value	Explanation	Further inform.
Measured value	Trip which caused shut down	89.01
Measured value	Code of active trips (hexadecimal)	89.02
Measured value	Code of active trips (hexadecimal)	89.03
Measured value	Code of active warnings (hexadecimal)	89.04
Measured value	Code of active+ warnings (hexadecimal)	89.05
Menu	Recent Trips Times (last 10)	89.06
Measured value	Recent Trip 1 (latest)	
Measured value	Recent Trip 2	
Measured value	Recent Trip 3	
Measured value	Recent Trip 4	
Measured value	Recent Trip 4	
Measured value	Recent Trip 6	
Measured value	Recent Trip 7	
Measured value	Recent Trip 8	
Measured value	Recent Trip 9	
Measured value	Recent Trip 10 (oldest)	
Menu	Recent Trips Times (last 10)	89.07
Measured value	Recent Trip Time 1 (latest)	
Measured value	Recent Trip Time 2	
Measured value	Recent Trip Time 3	
Measured value	Recent Trip Time 4	
Measured value	Recent Trip Time 5	
Measured value	Recent Trip Time 6	
Measured value	Recent Trip Time 7	
Measured value	Recent Trip Time 8	
Measured value	Recent Trip Time 9	
Measured value	Recent Trip Time 10 (oldest)	
Measured value	Control board powered-up time (to time-stamp trips if no RTC)	89.08
Measured value	Reset to 15(F) after running 5x 70:VsC_tinhibit_TIME	89.09
Measured value	t remaining until next start attempt AR: Auto Restart	89.10
Measured value	Extension Module: Trips_Warnings	89.11

- Trips:

Warnings:

Trips:

Times:

First Trip: NONE

Active 1 - 32: XXXXXXXX

Active 33 - 64: 000000XX

Warnings 1 - 32: XXXXXXXX

Warnings 33 - 64: 000000XX

Recent Trips[]: >>

Recent Trips[0]: NONE

Recent Trips[1]: NONE

Recent Trips[2]: NONE

Recent Trips[3]: NONE

Recent Trips[3]: NONE

Recent Trips[5]: NONE

Recent Trips[6]: NONE

Recent Trips[7]: NONE

Recent Trips[8]: NONE

Recent Trips[9]: NONE

Recent Trip Times[]: >>

Recent Trip Times[0]: YYYYYYYY s

Recent Trip Times[1]: YYYYYYYY s

Recent Trip Times[2]: YYYYYYYY s

Recent Trip Times[3]: YYYYYYYY s

Recent Trip Times[4]: YYYYYYYY s

Recent Trip Times[5]: YYYYYYYY s

Recent Trip Times[6]: YYYYYYYY s

Recent Trip Times[7]: YYYYYYYY s

Recent Trip Times[8]: YYYYYYYY s

Recent Trip Times[9]: YYYYYYYY s

Control Board Up Time: YYYYYYYY s

AR Restarts Remaining: YY

AR Time Remaining: YYYYYY.Y s

EM-: Trips Warnings: YYY YYY

FAULTS / WARNINGS

Trips, Diagnosis, Fault Finding

Trip Message	Possible Cause	Hints for Fault Finding	Remedies
01 OVER VOLTAGE	<ul style="list-style-type: none"> Voltage of supply too high Compressor motor defect 	<ul style="list-style-type: none"> Measure and document three input voltages Test Compressor motor. Disconnect cables from the Refrigeration Inverter. Connect direct to the input supply through a suitable motor circuit breaker. Monitor if compressor runs normally by verifying current taken agrees with compressor manufacturer's data. Measure resistance of motor winding and compare with manufacturer's data Disconnect Refrigeration Inverter and check winding insulation between phases and to earth Check wiring of control circuit and compare function with recommendations 	<ul style="list-style-type: none"> Rectify cause of any high voltage Replace compressor motor Modify wiring
02 UNDER VOLTAGE	<ul style="list-style-type: none"> Voltage of supply too low Phase of supply voltage missing 	<ul style="list-style-type: none"> Measure and document three input voltages 	<ul style="list-style-type: none"> Rectify cause of any low voltage
03 OVER CURRENT	<ul style="list-style-type: none"> Isolating contactor not controlled correctly 	<ul style="list-style-type: none"> Check wiring of control circuit and compare function with recommendations 	<ul style="list-style-type: none"> Modify wiring
04 STACK FAULT	<ul style="list-style-type: none"> Compressor motor defect 	<ul style="list-style-type: none"> Test Compressor motor. Disconnect cables from the Refrigeration Inverter. Connect direct to the input supply through a suitable motor circuit breaker. Monitor if compressor runs normally by verifying current taken agrees with compressor software data. 	<ul style="list-style-type: none"> Replace compressor motor
05 STACK OVER CRRNT			
21 PHASE FAIL		<ul style="list-style-type: none"> Measure resistance of motor winding and compare with manufacturer's data 	
22 VDC RIPPLE	<ul style="list-style-type: none"> Refrigeration Inverter faulty Incorrect motor connection 	<ul style="list-style-type: none"> Disconnect Refrigeration Inverter and check winding insulation between phases and to earth Remove motor cable connections to Refrigeration Inverter Check if operation of Refrigeration Inverter without a motor connected is possible Test operation with a small test motor Check wiring to motor terminals (choice of star/delta, part winding etc.) 	<ul style="list-style-type: none"> Replace Refrigeration Inverter Modify wiring
08 INVERSE TIME	<ul style="list-style-type: none"> Compressor start aborted 	<ul style="list-style-type: none"> Liquid refrigerant in compressor? Defect compressor 	<ul style="list-style-type: none"> Contact Supplier for advice
09 MOTOR I2T			
14 START FAILED		<ul style="list-style-type: none"> Incorrect size of Refrigeration Inverter or motor connected in delta instead of star 	
27 STO ACTIVE	<ul style="list-style-type: none"> Safety circuit tripped. Problem with ext Safety Module Safety relay or contactor not controlled correctly Wiring fault in safety circuit DC 24 V control voltage missing 	<ul style="list-style-type: none"> Check safety circuits. Possibly missing supply voltage at a monitoring device. Check wiring of control circuit and compare function with recommendations Check DC 24 V control voltage at Refrigeration Inverter Short circuit with DC 24 V control voltage ? 	<ul style="list-style-type: none"> Reset if necessary Verify wiring Modify wiring Verify wiring
33 PRESSURE TRANSMITT	<ul style="list-style-type: none"> Suction-pressure transmitter not connected or connections swapped Transmitter suction pressure faulty Verify setting Sp0 (p. 6) 	<ul style="list-style-type: none"> Check if blue LED at the input of the Basic Module lights Check if blue LED at the input of the Basic Module lights Ratiometric Types: Check connections 	<ul style="list-style-type: none"> Verify correct connection of suction pressure transmitter. Exchange leads if necessary Replace faulty pressure transmitter
34 PRESS RANGE EXCEED	<ul style="list-style-type: none"> Pressure outside range or unsuitable pressure transmitter fitted 	<ul style="list-style-type: none"> Verify Pressure Transmitter 	<ul style="list-style-type: none"> Exchange Pressure Transmitter or correct wiring
35 DISCH TEMP TOO HGH	<ul style="list-style-type: none"> Discharge-gas temperature too high 	<ul style="list-style-type: none"> Suction-gas superheat too high Damaged compressor valves or leaking gasket Unsuitable refrigerant 	<ul style="list-style-type: none"> Investigate refrigeration components
36 SUPERHEATS TOO LOW	<ul style="list-style-type: none"> Suction and Discharge-Gas superheats too low 	<ul style="list-style-type: none"> Problem with an expansion valve Liquid in suction line 	<ul style="list-style-type: none"> Investigate refrigeration components
37 LUBRC TEMP TOO LOW	<ul style="list-style-type: none"> Lubricant Overtemperature too low 	<ul style="list-style-type: none"> Suction-gas superheat too low Liquid in suction line Sump heater not used, not connected correctly or faulty 	<ul style="list-style-type: none"> Investigate refrigeration components
38 LUBRC PRES TOO LOW	<ul style="list-style-type: none"> Low lubricant pressure 	<ul style="list-style-type: none"> Lubricant migration Problem with refrigeration piping 	<ul style="list-style-type: none"> Investigate refrigeration circuit
39 EXT MODULE FAULT	<ul style="list-style-type: none"> External Module or cable fault 	<ul style="list-style-type: none"> Verify wiring 	<ul style="list-style-type: none"> Correct wiring
40 MAINTENANCE NECESS	<ul style="list-style-type: none"> Proactive Maintenance due 	<ul style="list-style-type: none"> Investigate Maintenance parameters in the menu DIAGNOSTICS 	<ul style="list-style-type: none"> Organize parts required and plan maintenance
?? OTHER TRIP	<ul style="list-style-type: none"> Other 		<ul style="list-style-type: none"> Contact supplier for advice

→ ELECTRICAL

REFRIGERATION ←

FAULTS / WARNINGS
COMMUNICATION
 DIAGNOSTICS

Menu COMMUNICATION for setting up Communications:
 View Level TECHNICIAN (for Refrigeration Personnel) only, see page 1

Type	Explanation	Further inform.
Value		

Settings Ethernet:

-Ethernet>

DHCP	TRUE
IP Auto	TRUE
User_IP_Address	FFF.FFF.FFF.FFF
User_Subnet_Mask	FFF.FFF.FFF.FFF
User_Gateway_Address	FFF.FFF.FFF.FFF

Ethernet local area network

Setting	Explanation	Value
Setting	Ethernet local area network	10.1.01
Setting	Automatic IP generation	10.1.02
Setting	User set IP address	10.1.03
Setting	User set Subnet Mask	10.1.04
Setting	User set Gateway Address	10.1.05

Previous three parameters only visible if DHCP or IP Auto are both set to FALSE

Settings RS485 Modbus RTU:

-RS485-Modbus>

Modbus Device Address	1
Modbus RTU Baud Rate	9600 BPS
Parity And Stop Bits	EVEN, 1 STOP
High Word First RTU	FALSE
Modbus RTU Timeout	3.0 s

RS485 Modbus RTU with Option Module A FU+ CM-1

Setting	Address	Value
Setting	Address	1..247
Setting	Baud Rate	1200..115200 BPS
Setting	Parity and Stop Bits	
Setting	16-Bit High-word first for 32-Bit interrogations	
Setting	No activity Timeout (Watchdog)	0.0 .. 65.0 s

Settings Ethernet Modbus:

Ethernet-Modbus>

Maximum Connections	2
High Word First	FALSE
Modbus Timeout	3.0 s
Modbus Conn Timeout	66 s

Modbus over ETHERNET

Setting	Maximum number of connections	Value
Setting	Maximum number of connections	10.3.01
Setting	16-Bit high-word first for 32-Bit interrogations	10.3.02
Setting	No Modbus RTU activity Timeout	0.0 .. 65.0 s
Setting	No Ethernet Fieldbus activity	0 .. 100000 s

Settings Ethernet Modbus:

-Comms_Control>

Refrig_Control_Word	0000
LODAM_Control_Word	0000
Refrig_Status_Word	YYYY
Comms_Reference	0.00 %
EM_Control_Word	0.00 %

Comms remote control

Setting	Refrigeration Comms Control Word	Value
Setting	Refrigeration Comms Control Word	10.4.01
Setting	LODAM Comms Control Word	10.4.02
Setting	Refrigeration Status Word	10.4.03
Setting	Comms Reference (Setpoint)	10.4.04
Setting	Extension Module Control Word	10.4.05

Modifying

Password TECHNICIAN for Refrigeration Personnel: 8670

Keypad FU+ PROG:



Key	Navigation Mode	Edit Mode
Softkey 1	Select level menu	-
Softkey 2	Select Data (p7), Select Information (p19)	-
UP	Moves up list of parameters, see also p19	Increments displayed parameter
DOWN	Moves down list of parameters, see also p19	Increments displayed parameter
LEFT	Prev. menu or parameter, see also p7 and p19	Selects the digit to be changed
RIGHT	Next menu or parameter, see also p7 and p19	Selects the digit to be changed
OK	Next level menu or parameter	Edit mode when a parameter is selected
'1' '0'	Refer to pages 7, 19	Refer to pages 7, 19

Menu, Diagnostics:
Diagnostics and other Monitoring Data

Diagnostics

COMMUNICATION
DIAGNOSTICS
TIME SCHEDULER

Sequencing and Limits:

SEQUENCR Refr VSD
YY Y

STARTS---ENABLES---
YYYY YYYY YYYY YYYY

LIMITING CONDITIONS
YYYY YYYY YYYY YYYY

Relative Rack Capacity (volume flow):

Electrical Values:

Temperatures:

Power Module:

Control Module:

Compressor:

Maintenance :

Avr_Rack-POWR_Actual_
YYY.Y % Y.YYY %

DC-LINK MOTOR
YYY V YYYV V

BASE-FRQ POWER
YY.Y Hz YYY.Y kW

Cntrl_Modl_Heat_Sink
YY.Y °C YY.Y °C

Power Stack Fitted
YYYYYYYYYYYYYY

Stack Serial No
YYYYYYYYYYYYYY

HV SMPS Up Time
YYYYYYYYYYYYYY s

HV Power On Count
YYYYYYYYYYYYYY

Control Module Serial
YYYYYYYYYYYYYY

Control Board Up Time
YYYYYYYYYY s

VsC_Serial_Number
YYYYYYYYYYYYYY

Motor Run Time
YYYYYYYYYY s

VFsC-numbr_Starts_nmb
YYYYYYYYYY

VsC_equiv_50_Hz_time_
YYYYYYYYYY s

Fan_equiv_40_°C_time_
YYYYYYYYYY s

Type Value	Explanation
Internal value	Left: RHVAC sequencer 0 .. 13, Right: Internal sequencer 0 .. 7
Left:	Right:
0:Stoppd Rly to Start	0:NOT_READY_TO_SWITCH_ON
1:Start Delay	1:SWITCH_ON_DISABLED
2:Autotuning	2:READY_TO_SWITCH_ON
3:Aligning	3:SWITCHED_ON
4:Prefluxing	4:OPERATION_ENABLED
5:Starting	5:QUICKSTOP_ACTIVE
6:Lubricating	6:FAULT_REACTION_ACTIVE
7:Hold_at_fmin	7:FAULTED
8:Normal operation	
9:Stopping	
10:Stopped, Inhibited	
11:Compressor Heating	
12:Local operation	
	13:Serial_communicatns
	15:Fault_not_cleared

Further Inform.
11.1

Internal value	Logical conditions:
xxxx xxxx xxx1	Safety Circuit (STO) Not active (OK)
xxxx xxxx xx1X	Refrigeration inverter Enabled (fault free)
xxxx xxxx x1XX	Ext. Module EM1..3,6..8 Enable or not present
xxxx xxxx 1XXX	ISESCO Enable or not present
xxxx xxxx xxx1	pe >> pe min limit Suction pressure
xxxx xxxx xx1X	ted > ted min Evaporating temperature
xxxx xxxx x1XX	tod < tod max Discharge temp
xxxx xxxx 1XXX	pc << pc max limit Exhaust gas pressure
xxxx xxx1	DI1 Start input
xxxx xx1X	ted > ted setpoint/ Force Controller start / DI2
xxxx x1XX	External Module EM1..3 Module start
xxxx 1XXX	ISESCO ISESCO start
xxx1	External Start Signal AI1 or AI2 > 0.0 V
xx1X	Compr. Swop active Swop time >= 0 s
x1XX	Compressor VFSc1 Available
1XXX	Compressor VFSc2 Available

Internal value	Logical conditions:
xxxx xxxx xxx1	tcd >= tcd max Condensing Temperature
xxxx xxxx xx1X	Suction Gas Superheat too low
xxxx xxxx x1XX	Discharge gas Superheat too low
xxxx xxxx 1XXX	Lubrication Overheat too low
xxxx xxxx xxx1	pl Lubrication Differential pressure
xxxx xxxx 1XXX	tenc Enclosure Too warm
xxxx xxx1	Envel. current limiting Active
xxxx xx1X	ted > tedmax Starting
xxxx x1XX	Rack increase fmin Too long at min capacity
xxx1	lcmp >= lcmp max Current
xx1X	LAS Low Ambient Start Active
x1XX	RAS Active

Measured value	Compressor Rack power:
___ %	Average_Actual:

11.2

Calculated values	DC Link and motor voltages
___ V	

Calculated value	Base Frequency Motor power
___ Hz	___ kW

Measured value	Heatsink and Control Module Temperatures
___ °C	___ °C

11.3

Measured value	Power Size Code

11.4

Measured value	Stack Serial Number

Measured value	Switched-Mode Power Supply ON time
___ s	

Measured values	Number of times the supply has been connected

Measured value	Control Board Serial Number

11.4

Measured value	Control board powered-up time in s
___ s	

Measured values	VsC Compressor Serial Number
___ s	

11.6

Measured values	Compressor ON time
___ s	

Measured values	Number of compressor and number of starts

Measured values	VsC Compr equiv. 50 Hz
___ s	

11.7

Password TECHNICIAN for Refrigeration Personnel with training

Keypad FU+ PROG:
Diagnosis:



Light	Explanation
OFF	Fast Flashing Stopping
OFF	ON Stopped, no Start input
ON	OFF Stopped, no refrigeration requirement
ON	OFF Running
Fast Flashing	OFF Auto Start pending, Starting
Slow Flashing	OFF Started, Inhibit Time running
Green then Red Flashing	Tripped / Fault

DIAGNOSTICS

POWER SECTION

Power connections

THESE DIAGRAMS TO BE REPLACED BY DIAGRAMS FOR FANS

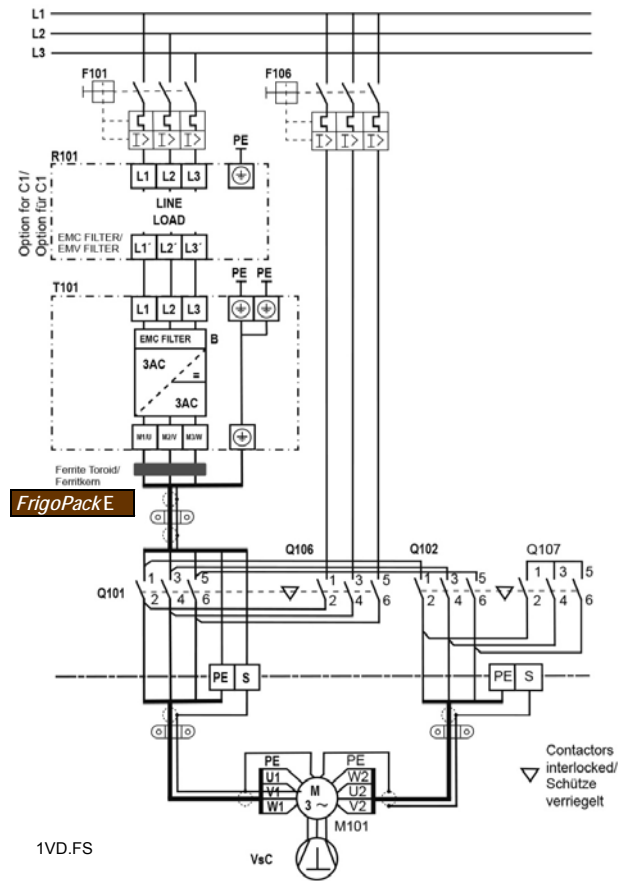
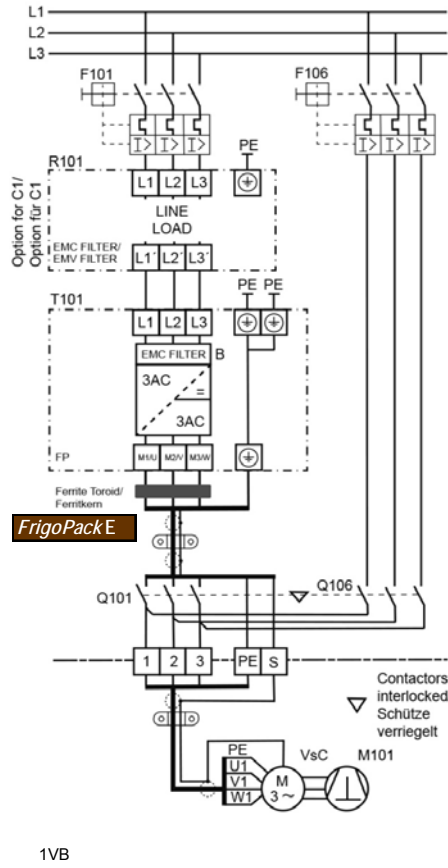
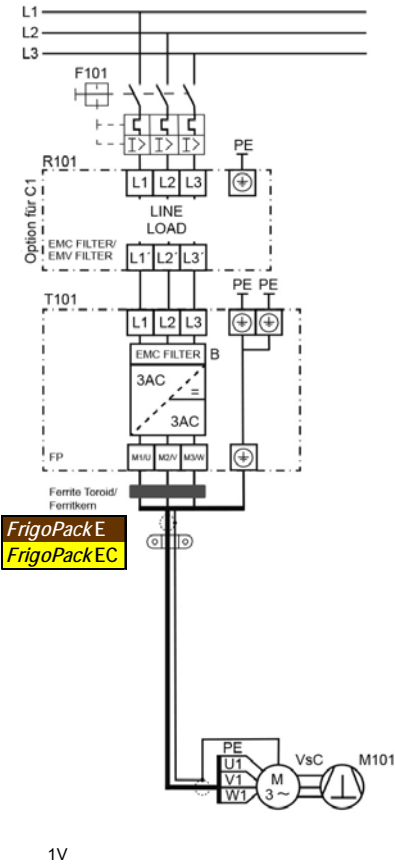

Single compressor

Settings: 80:Fsc PRIORITY
Dt8:

Single compressor with bypass (for emergency operation)

0000000 (See page 4)
DCFA8008 (See page 5)

Single compressor in DELTA with bypass in STAR (for emergency operation)

Digital Control Outputs		Place/Part
Relay DO1	Ready:	FrigoPack FrigoPack
Relay DO2	Operation:	FrigoPack FrigoPack
Relay DO3	Expansion (recommended)	FrigoPack

POWER SECTION

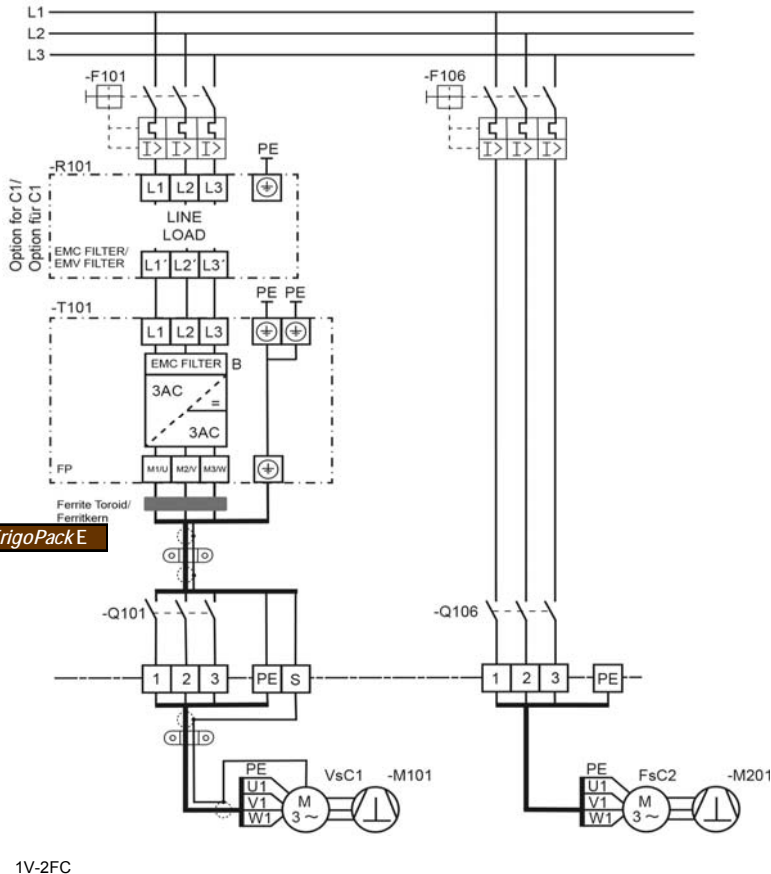

Variable-speed compressor + second larger compressor with Capacity Control

Settings: 80:Fsc PRIORITY 00000001 (See page 4)
Dt8: 08A9F008 (See page 5)

* Accessory required:

FsC2/CC:

A FU+ DC12V RL/11 (Special low coil-current relay module)

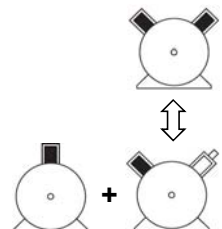

Digital Control Outputs		Place/Part
Relay DO1	Ready:	FrigoPack FrigoPack
Relay DO2	Operation:	VsC1 FrigoPack
Relay DO3	Operation:	FsC2 FrigoPack
Relay DO4	Capacity Control	Extern.P24 V
Relay AO2	Expansion (recommended)	Ext. P12 V *

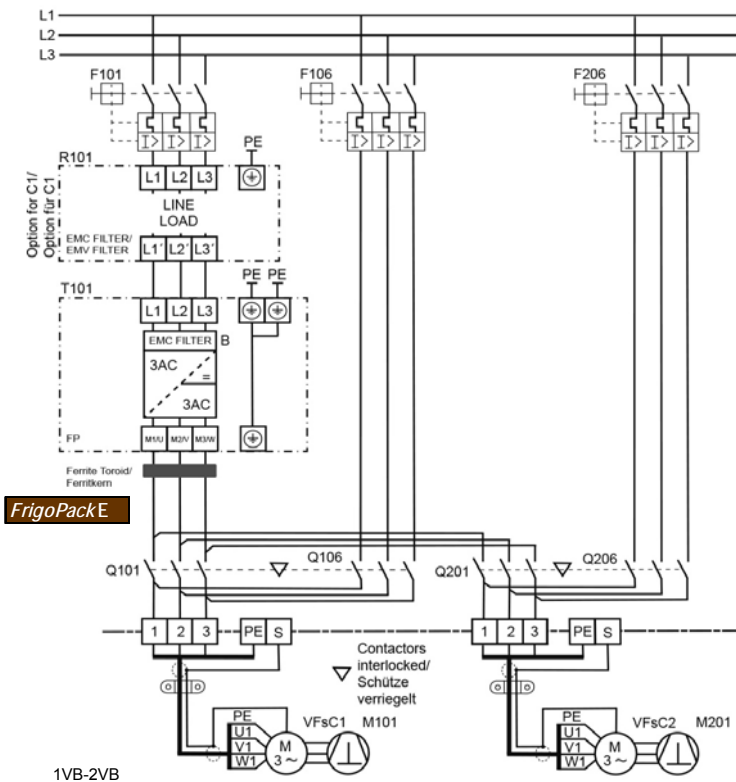

1VB-2VB

Two compressors, each with bypass and rotation

Digital Control Outputs		Place/Part
Relay DO1	Ready:	FrigoPack
Relay DO2	Operation:	VFSc1
Relay DO3	Operation:	VFSc2
Relay AO2	Expansion (recommended)	Extern.P24 V

Note:
This connection requires a special arrangement of auxiliary contacts on the contactors. Alternatively a special control module from KIMO RHVAC Controls may be used.

Settings:

80:FsC _____ PRIORITY 000000**EE** / (See page 4)
000000**FF**
Dt8: _____ **DCB**8008 (See page 5)

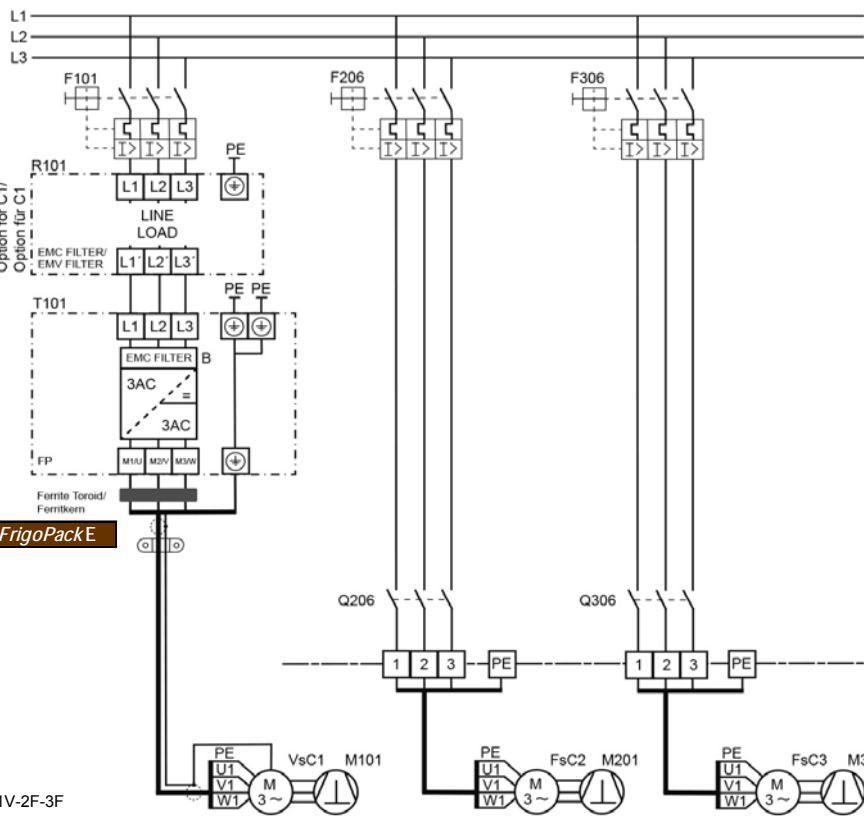

1V-2F-3F

Three compressors, two Fixed-speed Compressors with rotation

Settings: 80:FsC _____ PRIORITY 000000**11** (See page 4)
Dt8: _____ **DCBA**F008 (See page 5)

* **Accessory required:** A FU+ DC12V RL/11 (Special low coil-current relay module)

Various other configurations are possible (e.g. up to 6 compressors), please enquire.

Power terminals

Terminal / Designation	Signal / Function	Explanation	Further information
PE	Protective Earth connection 1 to supply	- Observe all safety and EMC requirements	7.7.1
L1	Three phases of voltage supply	- Ensure that supply voltage agrees with data on name plate	7.7.1
L2			
L3			
PE	Protective Earth connection 2 to supply	- Observe all safety and EMC requirements	6.7
M1/U	Motor of Variable-speed Compressor	- Through interlocked isolating contactor if required	7.7.1/
M2/V			7.7.2
M3/W			
PE	Protective earth connection to compressor motor		7.7.2

POWER SECTION

CONTROL SECTION

FrigoSoft 4.7 activated: External Control with 0..10 V / 4..20 mA

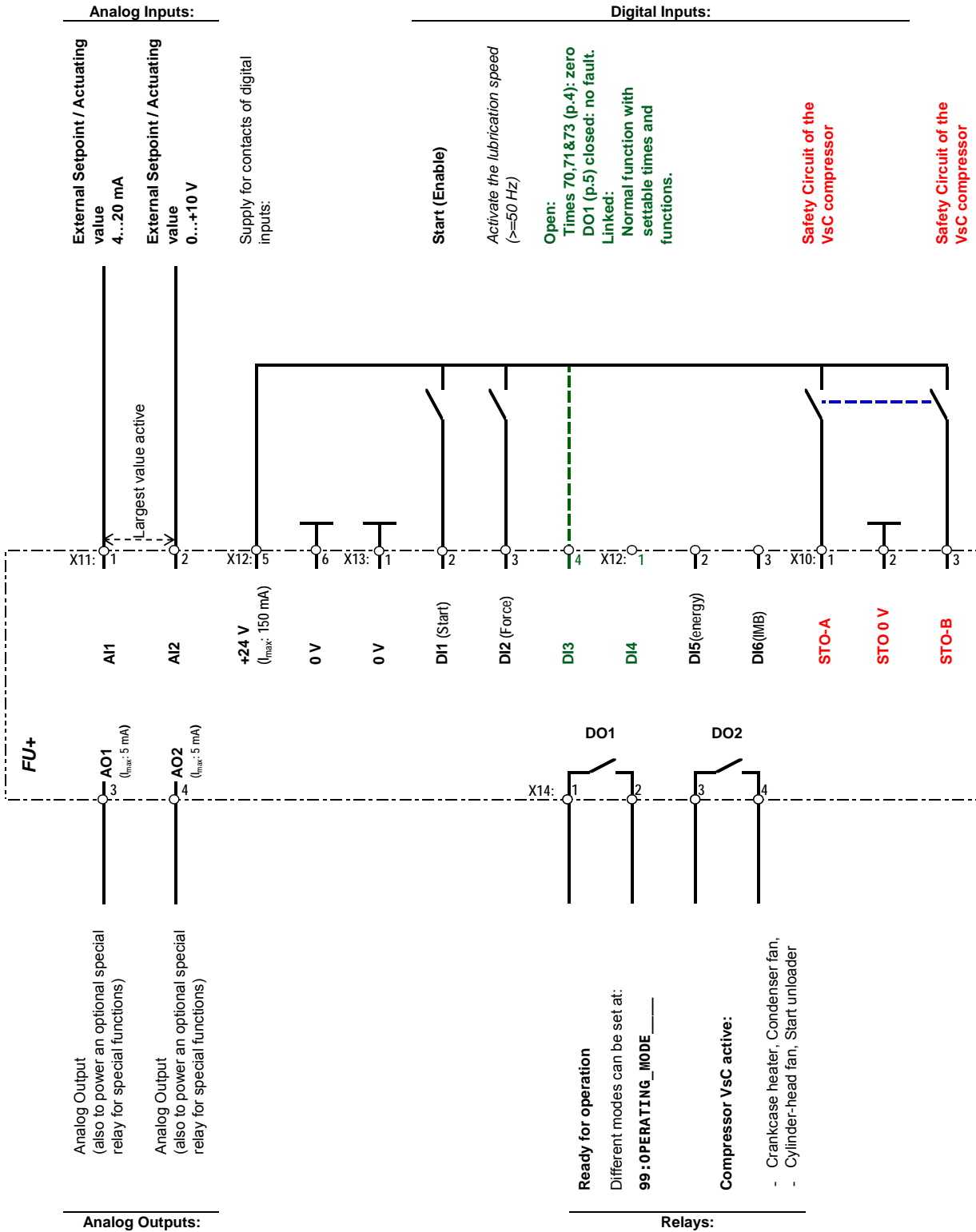

VsC: Variable-speed Compressor

Connection with the functional earth required - e.g. a wire connection to an earth terminal

Terminal position:

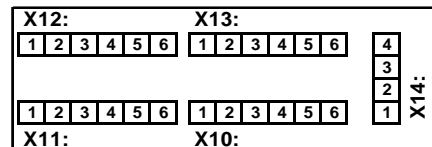

Terminal List for control functions

FrigoSoft 4.7 activated: External Control with 0..10 V / 4..20 mA

Terminal / Designation	Signal / Function	Explanation	Further information
X13.1	0 V	Ground for analog signals	
X11.1	AI1	Analog Input: External controller, Speed 4...20 mA 4...20 mA: fmin ... fmax <3.5 mA: Fault	- Alternative usage (largest wins)
X13.2	AI2	Analog Input: External controller, Speed 0...+10 V 0...+10 V: fmin ... fmax	- Alternative usage (largest wins)
X11.5	P10 V	Universal Analog Output (5 mA max. load)	- Do not use
X11.6	N10 V	Universal Analog Output (5 mA max. load)	- Do not use
X12.5	+24 V	Supply for contacts of digital inputs	
X13.2	DI1	Digital Input: Start (Enable) +24 V: Start 0 V: Controlled stop	- Must be used: - Load: 3.3 kΩ, 7.3 mA
X13.3	DI2	<i>Digital Input:</i> <i>Activate Lubrication Speed (50 Hz)</i> +24 V: Lubrication speed 0 V: Normal operation	- <i>Optional use</i>
X13.4	DI3	Digital Input: Normal function with adjustable times +24 V: Times 70: 71: & 72: normal and adjustable, 99: D100 (Delay OFF 15 min) 0 V: Times 70: 71: & 72: 0 s fixed (e.g. for WURM), 99: 1100 (no fault)	- Connect to +24 V at terminal X12:5 - Verify Parameters 70: 71: 72 & 99: are correctly set
X12.1	DI4	Digital Input: Do not use	
X12.2	DI5	Digital Input: Pulses from Energy Meter +24 V: Pulse 0 V: Not activated	- Optional use
X12.3	DI6	Digital Input: Identification Module BM-1 (>=50 Hz) +24 V: IMB Coding (mark) 0 V: IMB Coding (space)	- Must be used: - <i>Connect to Module BM-1, terminal X4.5</i>
X10.1	STO-A	Digital Input STO (Safe Torque Off), Channel A +24 V: Operation Enable 0 V: Safe Stop	- Must be used: - Enable from contact pair of safety relay - Active if Channel B simultaneously activated - Load: 3.3 kΩ, 7.3 mA
X10.2	0 V	Functional earth for Safe Torque Off	- Must be used
X10.3	STO-B	Digital Input STO (Safe Torque Off), Channel B +24 V: Operation Enable 0 V: Safe Stop	- Must be used: - Enable from contact pair of safety relay - Active if Channel A simultaneously activated - Load: 3.3 kΩ, 7.3 mA
X14.1 / X14.2	DO1	Relay Output: "Ready" (without fault) Closed: Ready (no fault) Open: No supply, fault or alarm	- Ready (no fault): - Function depends on the following setting SPECIAL_ADJUSTMENTS_ DATA Dt1 - Max load: AC 230 V / 250 VA
X14.3 / X14.4	DO2	Relay Output: - Single compressor: - Activate VsC1 (Operating) Closed: Operation / Activate Open: Stop, Deactivated	- To control auxiliaries such as: Crankcase heater, Condenser fan, Start unloader - Max load: AC 230 V / 250 VA
X11.3	AO1	Analog Output with alternative functionality: Frequency 0...+10 V: 0.0 ... 100.00 %	- Function depends on the following setting: SPECIAL_ADJUSTMENTS_ Dt8 - Max load: 5 mA
X11.4	AO2	Analog Output with alternative functionality: Hot-gas Bypass control 0...+10 V: 0.0 ... 100.00 %	- Function depends on the following setting: SPECIAL_ADJUSTMENTS_ Dt8 - Max load: 5 mA

VsC: Variable-speed Compressor
FsC: Fixed-speed Compressors
CC: Capacity Control

VfG: Variable-speed fan group
(Condenser / Dry cooler)

Control and Safety Circuits

FrigoSoft 4.7 activated: External Control with 0..10 V / 4..20 mA:

The regulations for refrigeration equipment reference the safety standard EN 60204-1 (Safety of machinery - Electrical equipment of machines - Part 1 General requirements).

It is established and proven practice that safety circuits (including pressure-limiting devices) are processed by electromechanical devices such as relays or contactors.

It is not permissible to use standard software-based automation controls (such as PLCs) as these are not functionally fail-safe or a software error can result in dangerous operating conditions.

In an emergency (such as a pressure-limit reached) the Stop Category 0 (immediate removal of power) is appropriate.

Contactors interruption in the energy supply to the compressor is a proven circuit technique for the immediate and safe stopping of compressor motors in an emergency condition.

The integrated Safe Torque-Off (STO) function of this Refrigeration Inverter may be used as an alternative method provided that a bypass contactor is not used. With correct installation a Safety Integrity Level of SIL3 can be achieved.

A typical safety circuit would normally consist of the following:

- Essential safety-relevant devices such as approved over-pressure switches
- Optional devices such as low-pressure switches, oil pressure or level monitoring controls

The safety circuit should terminate at a safety relay with two normally-open contacts wired as follows:

- Two individual or a single common connection from P24 V from the Refrigeration Inverter to the supply side of these two contacts.
- Two independent normally-open contacts dedicated to the Safe-Torque Off function of the refrigeration inverter wired to inputs STO-A and STO-B

The previously described standards and recommendations are general guidelines for the safety-relevant design of the installation.

However it is the installer or contractor's responsibility to assess the risk of each installation and to ensure that all safety measures are appropriate and functional.

Functional recommendations

A control switch should be provided with the following functionality:

- Middle position: **OFF** Controlled STOP of the compressor or compressor rack
- Right position: **AUTO** AUTOMATIC controlled operation
- Left position: **MAN** MANUAL test or emergency operation without activation of the Refrigeration Inverter

The normal automatic stopping and starting of the compressor should only be by using the AUTOMATIC (start) command at Digital Input DI1 of the Refrigeration Inverter.

Opening contactors in the input or output of the Refrigeration Inverter during operation must not be used for normal starting or stopping of the compressor as this will stress the Refrigeration Inverter and reduce the working life.

To ensure correct monitoring and fault logging the operating commands should be separate from the safety circuit.

The MANUAL mode of operation should preferably make use of a pump-down pressure switch to enable controlled operation.

It is recommended that control circuit automatically reverts to MANUAL operation if the FrigoPack Refrigeration Inverter is not available. This condition should be signalled to a supervising or warning system.

If in a fault condition no compressor is available, then a means of stopping the evaporation is recommended to minimize the risk of liquid in the suction line should be provided.

Example of suitable safety and control circuits

The following simplified overview of the safety and control wiring of a typical system only includes the wiring for AUTOMATIC operation.

Suggestions for the safety and control wiring with these features are available on request.

Please enquire at your supplier for assistance with the planning of complex systems or systems with special requirements.

SAFETY CIRCUIT

FrigoSoft 4.7 activated: External Control with 0..10 V / 4..20 mA:

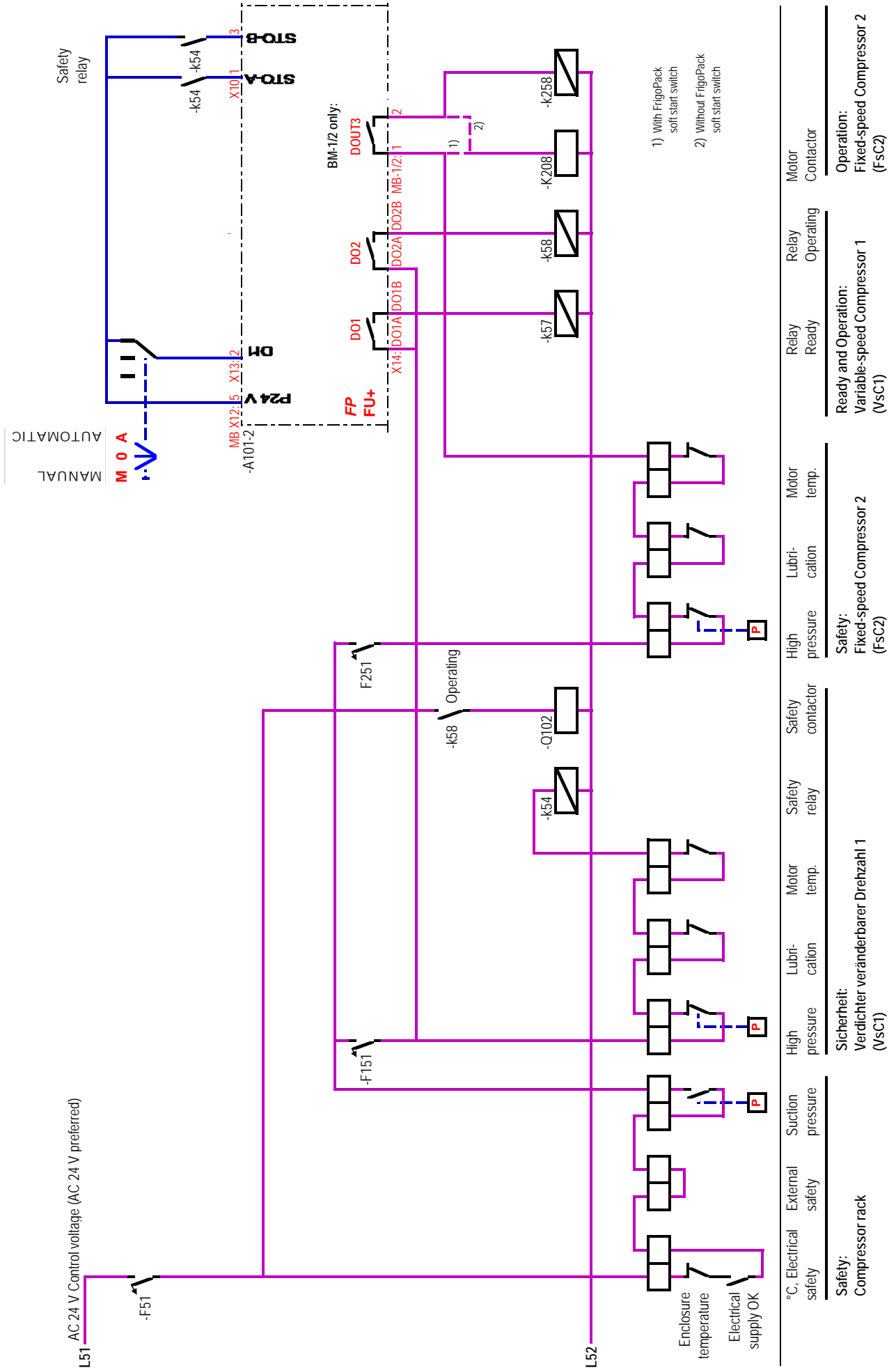

FIRST-TIME POWER UP

Mounting and electrical safety:

Ensure that all recommendations in the Product Manual have been adhered to.

UL compliance where appropriate:

Ensure that all recommendations in the Product Manual for UL compliance have been adhered to.

EMC compliance:

Ensure that all recommendations in the Product Manual for EMC compliance have been adhered to.

View Level:

There are three basic view levels selectable in the Wizard (see page 2):

OPERATOR:

Available without password as it is not possible to change any settings at this level.

TECHNICIAN:

For refrigeration-trained and authorized personnel (Password 8670). This level is sufficient for normal commissioning.

ENGINEER:

Special applications and usage (special Super-User password).

Language:

The language selection is only relevant when the 4-line Graphic Key Pad is fitted to the inverter

The following languages can be selected (see page 2):

English, German

(French, Spanish and Italian in preparation)

FrigoSoft® 4.7: No upper module fitted.

Operation with an external controller.

The control input can be alternatively

4 ... 20 mA at AI1 or 0 ... +10 V at AI2.

If both are applied then largest input wins control over the refrigeration inverter

Recommended basic commissioning steps:

- Verify that the power circuit corresponds to the suggestions on the previous pages 12/13
- In particular ensure that an interlocked safety contactor is fitted between the Refrigeration Inverter and the compressor if a parallel bypass connection is used.
- Verify that the control circuit corresponds to the suggestions on the previous pages 14...16.
- In particular ensure that two isolated contacts of the safety relay are connected to the Safe Torque Off inputs of FrigoPack: STO-A (Terminal X10.1) / STOP-B (Terminal X10.3)
- Remove Start Input: DIN1: X13:2.
- Connect main power supply.
- Verify that the blue LED for Suction Pressure near terminals BM-1: 1 & 2 lights. If not, then check that the wiring to the pressure transmitter is correct
- If a high-pressure pressure transmitter is used, then verify that the red LED near terminals BM-1: 3 & 4 for the high pressure lights. If not, then check that the wiring
- Measure the pressures with a pressure gauge. Verify that the pressure indicated at parameters 03:pe___VsC_pc_PRESS agree with these external measurements.

Recommended basic commissioning steps (cont.):

- Set the Refrigerant at the following parameter:
FIRST_SETUP _____ | SD-Card:Data_Select__ |
<1:Refrigerant _____
as described on pages 7,20
- Set the Compressor at the following parameter:
FIRST_SETUP _____ | SD-Card:Data_Select__ |
<2:VFsc_Manufactur _____
<3:VFsc_Type _____
<4:VFsc_Cylinders _____
<5:Motor_Voltage _____
<6:VFsc_Compressor _____
<<<TO_ENTER_DATA>>>
as described on pages 7,20
- Reset to the following starting position (IMPORTANT):
FIRST_SETUP _____ | SD-Card:Data_Select__ |
<0:Selection_disbl _____

MULTI-FUNCTIONAL SPECIAL KEYS 'I' & 'O' AND SOFT KEYS

Timed Operation:	Key:	Action:	Explanation:
------------------	------	---------	--------------

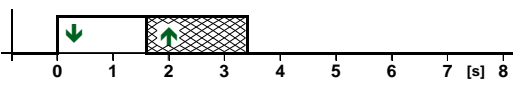

Reset Inhibit Timer: Digital Eing. DE1 (start): Start ==> Stop ==> Start
Only if in View Level ENGINEER

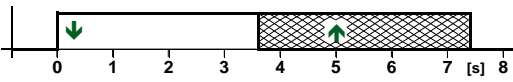

Modify ted setpoints to correspond to: Press Green Key 5 s and release:
See page 3:
31:ted_SETPOINT_1_____

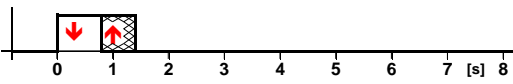

Reset trip and Autorestart: Press Red Key 1 s and release

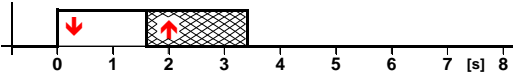

Stop and LOCAL reset: Press Red Key 2 s and release

Restart will occur automatically when the inhibit time is expired

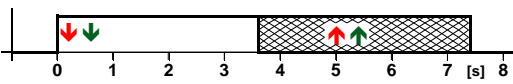

Interrogate Project Description: Navigate to FrigoPack_FU+ / 12 Welcome Menu

Press GREEN+RED Key together 2 s and release

Refrig. Softw., language:	+10 s ↓ /	1-FrigoSft 1.7.2
File:	+10 s ↓ /	2-FS27_18a_____
Initials, Date created:	+10 s ↓ /	3-JPG:01.07.2019
TEST and DEMO Modes:	+10 s ↓ /	4- !TEST-MODE 0!_
- LOCAL Mode automatic: Ramp-up and ramp-down:	Change direction with LEFT / RIGHT keys, see below	4- !TEST-MODE+2!_ Deactivate DI1 first
- LOCAL Mode manual: Increase or decrease speed	LEFT / RIGHT keys: Change speed, see below	4- !TEST-MODE+1!_ Deactivate DI1 first
- Back to Welcome Menu:	+10 s ↑ /	4- !TEST-MODE 0!_
- TEST / DEMO Mode -1:	Simulated pressure values, uses set compressors:	4- !TEST-MODE -1!_ Activate DI1
- TEST / DEMO Mode -2:	Modified pressure values, uses set compressors:	4- !TEST-MODE -2!_ Activate DI1
- PROD Mode -3:	Production: shorter times:	4- !TEST-MODE -3!_

Reset various values: Press GREEN+RED Key together and hold Refer to SPECIALS | SpJ on page 6:

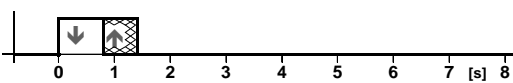

Increase LOCAL speed: Press LEFT Key 1 s and release +1 Hz

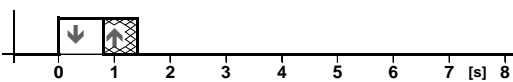

Reduce LOCAL speed: Press RIGHT Key 1 s and release -1 Hz

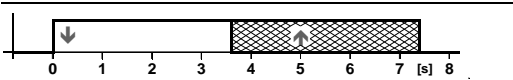

Reset to top level: Press Right Soft Key 5 s and release

FIRST-TIME POWER UP

Keypad display in TEST and DEMO Modes:

Mode	4- !TEST-MODE+1!_	Basic Module
Evaporat.: ted	Y.Y °C YY.Y °C	tcb :Condens.
Start	YYYYYYYY YYYY	State
Electrical: Elec	Y.Y Hz Y.Y A	Elec

View Level TECHNICIAN or ENGINEER required in this range:
Navigate between -3 -- +2 with UP / DOWN keys.

Setting-up step by step

Starting condition:

SD-Card:Data_Select	<0:Selection_disblD
SD-Card:Data_Read	<NORMAL OPERATION>

05|FS+|01.01a

1: REFRIGERANT:

Not available with FrigoSoft 4.7

STEP 1

Set Refrigerant selection mode:

SD-Card:Data_Select	
---------------------	--

Modify as follows if necessary:

Select Refrigerant:

SD-Card:Data_Read	<14:R134aHFC
-------------------	--------------

- Forwards

Backwards -

PRESS SOFTKEY ABOVE LEFT ON KEYPAD TO EXIT
=>DO NOT CONTINUE WITH FOLLOWING UNLESS NEW COMPRESSOR DATA REQUIRED

2: COMPRESSOR:

2

Compressor pre-selections:

2a.



Set Manufacturer selection mode:

SD-Card:Data_Select	<2:VFsc_Manufactur
---------------------	--------------------

Modify as follows if necessary:

Select manufacturer:

SD-Card:Data_Read	<21:BITZER
-------------------	------------

- Forwards

Backwards -

2b.



Set Type selection mode:

SD-Card:Data_Select	<3:VFsc_Type
---------------------	--------------

Modify as follows if necessary:

Select Type:

SD-Card:Data_Read	<32:Recip_Semihermtc
-------------------	----------------------

- Forwards

Backwards -

2c.



Set no of cylinders (0: screw or scroll):

SD-Card:Data_Select	<4:VFsc_Cylinders
---------------------	-------------------

Modify as follows if necessary:

Select no.:

SD-Card:Data_Read	<44:4_cylinders
-------------------	-----------------

- Forwards

Backwards -

2d.



Set Supply voltage:

SD-Card:Data_Select	<5:Motor_Voltage
---------------------	------------------

Motor voltage (NOT SUPPLY VOLTAGE):
Modify as follows if necessary:

Select supply voltage:

SD-Card:Data_Read	<53:50_Hz_400_V
-------------------	-----------------

- Forwards

Backwards -

2e.



Set Compressor selection mode:

SD-Card:Data_Select	<6:VFsc_Compressor
---------------------	--------------------

Modify as follows if necessary:

Select compressor:

SD-Card:Data_Read	<<2CES-4-40S
-------------------	--------------

- Forwards

Backwards -

2f.

Enter selected data:

SD-Card:Data_Select	<<<TO_ENTER_DATA>>>
---------------------	---------------------

To activate:

SD-Card:Data_Read	<<<PRESS_KEY_" ">>>
-------------------	---------------------

2a .. 2f

STEP 2

→4

Select menu:

OPERATION	
-----------	--

Verify settings:

25: REFRIGERANT	
<14:R134a	HFC

60: COMPRESSOR	
<6	2CES-4Y

Example compressor

Enter and verify compressor data:

Expert Overview

Not available with FrigoSoft 4.7

DIAGNOSTICS	
EXPERT OVERVIEW	
OPERATION	

02:ted_RACK_tcd	Y.Y °C	YY.Y °C
04:ted_RACK_tcb_Diff	Y.Y K	Y.Y K
08:Start	S1-Lm-Cp	YYYY YYYY YYYY
09:VsC_ELECTRICAL	Y.Y Hz	Y.Y A

Time Scheduler

Type	Value	Explanation	Further inform.
Calculated values	___ °C	Saturated gas temperatures (dew): Evaporating and Condensing	9.01
Deviations	___ K	Temp. Deviations from setpoints: Evaporating and Condensing	9.02
Status values		Right: Seq.-Lmts-CpctyCntrl-Compr Left: ARS--AttmptsLeft-Time to start	9.03
Measured values	___ Hz	Variable-speed Compressor, Motor Frequency and Current	9.04

Time scheduler

Not available with FrigoSoft 4.7

Under Development

DIAGNOSTICS	
TIME SCHEDULER	
EXPERT OVERVIEW	

Schdl_Wkdy_tcb_tev	YYYY
Hours_Minutes_Seconds	YY:YY:YY

Type	Value	Explanation	Further inform.
States		Schdule (15..0) Weekday (6..0) tcb tev	10.01
Time	__:__:__	Hours:Minutes:Seconds	10.02